

## PRESSURE RELIEF VALVES

### AM3 -MO-\*

60 l/min - 32 MPa (320bar)

#### 1 DESCRIPTION

Stackable pressure relief valve direct operated. The valve is made with a steel body combined with a pressure relief cartridge valve with an anti vibration system.

The body of the valve is phosphate coated. The cartridge valve is zinc coated.

The pressure can be set in different pressure ranges.

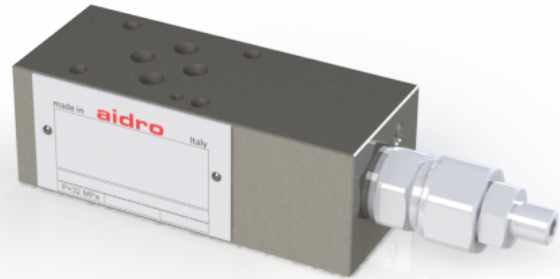

#### 2 ORDERING CODE

(1)	(2)	(3)	(4)	(5)	(6)	(7)
AM3	-	MO	-	-	-	/ 10

(1) AM3: stackable valve CETOP 03 - Pressure 32 MPa (320bar)

(2) MO: pressure relief, direct acting

(3) Service lines where the controls operate:

P: relief on P and discharge to T

B: relief on B and discharge to T

BA: independent relief on B and on A and discharge to T

(4) Pressure adjustment ranges:

10: from 2,5 MPa to 12,5 MPa (from 25 to 125bar)

20: from 4 MPa to 25 MPa (from 40 to 250bar)

32: from 10 MPa to 32MPa (from 100 to 320bar)

(5) Pressure adjustment range for relief on A  
(only for models AM3-MO-BA) see 4

(6) Code reserved for more options and variants

(7) Design number (progressive) of the valves

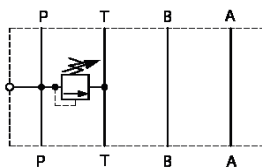
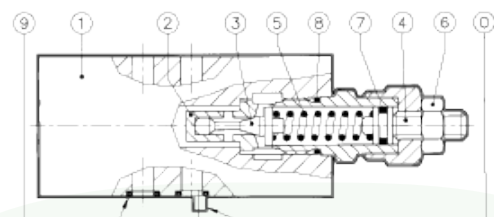
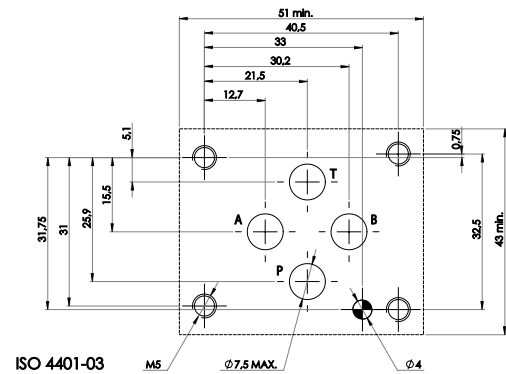

AM3-MO-P

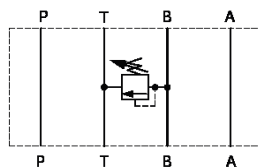

AM3-MO-B

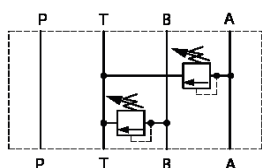

AM3-MO-BA

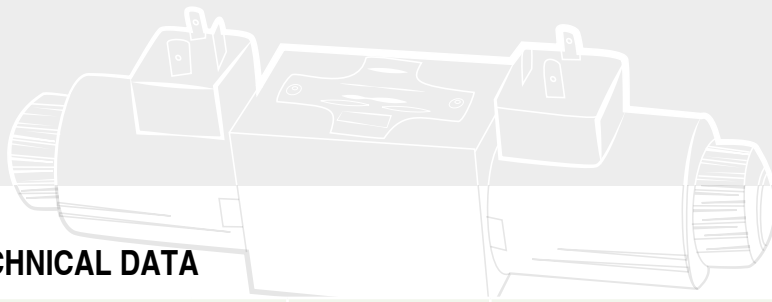

### 3 TECHNICAL DATA

Maximum nominal flow		Adjustment of the relief pressure:
Maximum rec. flow rate on free lines	1 dm <sup>3</sup> /s (60 l/min)	Relief pressure is reached when the axial hydraulic forces on piston 3 equal the force of spring 5; the value of the relief pressure can be therefore changed, within the limits of the chosen adjustment range, by changing the compression of spring 5. To increase the relief pressure, turn clock wise the adjustment screw 4, after having unlocked ist nut 6. For each pressure adjustment range, the pressure gradient is approx: 10: 1,6MPa/mm (24bar/turn) 20: 3,2MPa/mm (48bar/turn) 32: 5MPa/mm (75bar/turn) When the required level of pressure is reached, lock the nut 6.
On protected lines	0,5 dm <sup>3</sup> /s approx 32 l/min	
Maximum nominal pressure	32 MPa (320bar)	
Pressure relief curves	see 4	
Installation and dimensions	see 5	
Masses		
AM3-MO-P or B	approx 1,7 kg	
AM3-MO-BA	approx 2,3 kg	

### 4 TYPICAL DIAGRAMS

Typical  $\Delta p$ -Q curves for valves AM3-MO-\* in standard configuration, with mineral oil at 36 cSt and at 50°C

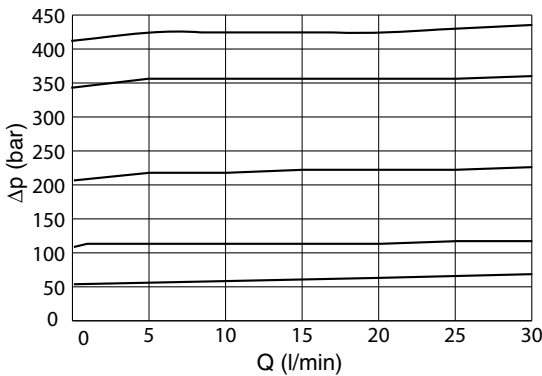

### 5 INSTALLATION DIMENSIONS (mm)

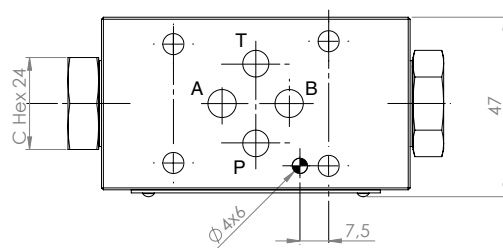
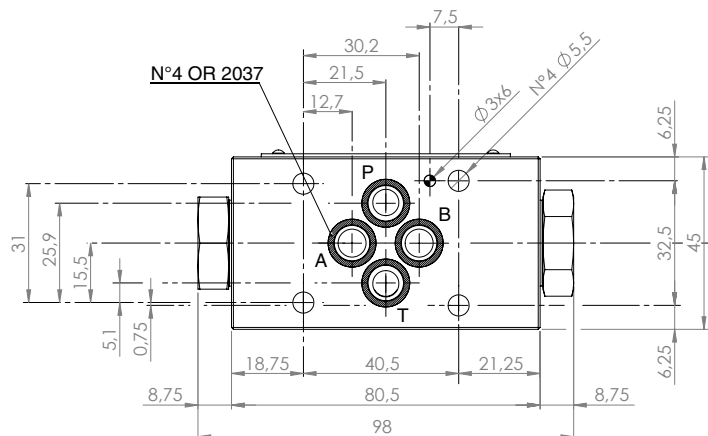

### 6 HYDRAULIC FLUIDS

Seals and materials used on standard valves AM3 - \*are fully compatible with hydraulic fluids of mineral oil base, upgraded with antifoaming and antioxidizing agents. The hydraulic fluid must be kept clean and filtered to ISO 4406 class 19/17/14, or better, and used in a recommended viscosity range from 10 cSt to 60 cSt.

All stackable valves AM3 - \* conform with ISO and CETOP specifications for mounting surface dimensions (see also front page). Valves height 40 mm. Leakage between valve and mounting surface is prevented by the positive compression on their seats of 4 seals of OR type. All valves have on their "mounting" surface a  $\phi$  3.4 mm cylindrical hole and have on their "seals" surface a  $\phi$  3 mm locating pin, to conform with the norms. In case of necessity, the pin can be easily removed.