

POWERRAM SPECIAL HAND PUMPS

Max. Working Pressure 700 bar / 10,000 psi
 Large 3/8" pressure port for maximum flow
 Low Handle effort for easy operation
 Two speed models



Model No.:P350A



Model No.:P350B

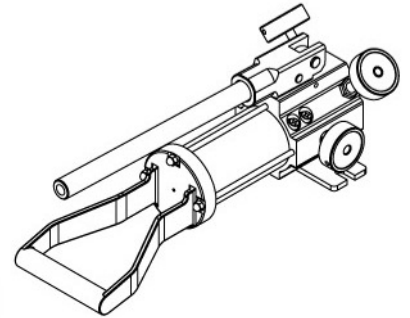
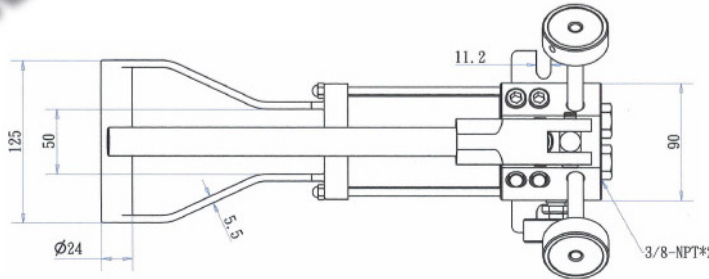

FEATURES:

- Jackram's hand pumps are always featured with their rugged construction and low handle efforts.
- Aluminum alloy construction and hand size release knob with anti-losing mechanism are truly suitable to industrial requirements and your daily works.
- Special design with aluminum alloy construction as much light weight is ideally for easy portability and maneuvering.
- Rubber oil reservoir design allows the hand pumps to be operated in all directions.
- Unique design of Triangle racket end create much easy pumping efforts.
- The patent pending design of P350B consolidating pump and manifold valve as one piece that makes much convenient job on operating two single-acting cylinders at the same time, but eliminating the extra needed adapters and accessories.

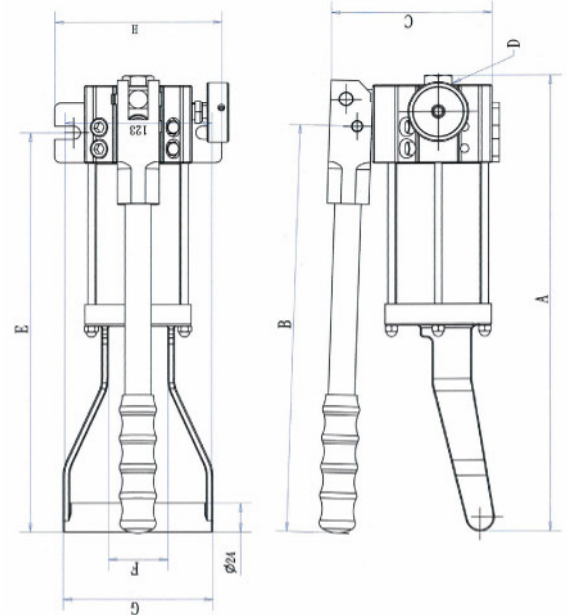

SPECIFICATIONS

Model No.		P350A	P350B
Pressure Rating	1st stage	13.8	13.8
	2nd stage	700	700
Usable Oil Capacity (c.c.)		350	350
Per Stroke (c.c.)	1st stage	13	13
	2nd stage	2.8	2.8
A (mm)		382	394
B (mm)		340	373
C (mm)		135	158
D (inch)		3/8-NPT	3/8-NPTx2
E (mm)		322	322
F (mm)		50	50
G (mm)		125	125
H (mm)		140	140
Weight (kgs)		3.7	3.9

Hoses & Adaptors



Page 47, 48

Manifolds & Control Valves



Page 47, 49, 50