

# HYDRAULIC NUT SPLITTERS

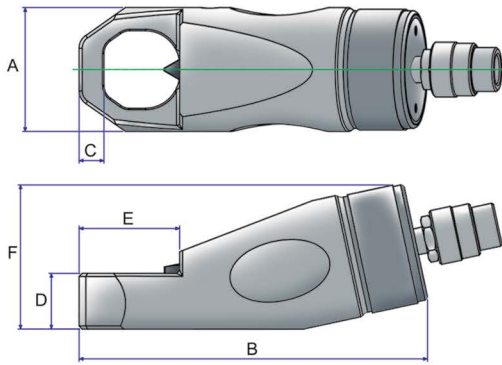

CAPACITY 10 ▶ 50 TON  
 MAXIMUM PRESSURE 10'000 PSI (700 BAR)  
 NUT RANGE 19mm ▶ 60mm



ORDER CODE	CAPACITY (ton)	NUT RANGE HEXAGON (mm)	BOLT RANGE (mm)	OIL CAPACITY (cm <sup>3</sup> )	A (mm)	B (mm)	C (mm)	D (mm)	E (mm)	F (mm)	WEIGHT (kgs)
HNS19	10	19 - 24	M12 - M16	20	60	167.2	10	25	40	68	2.1
HNS24	15	24 - 32	M16 - M22	60	70	178	13	30	52	76	3.1
HNS32	20	32 - 41	M22 - M27	80	80	226	15	36	65	93	4.2
HNS41	35	41 - 50	M27 - M33	155	95	244	21	45	76	106	8
HNS50	50	50 - 60	M33 - M39	240	106	269	24	55	92	125	11.5

# HYDRAULIC SPREADERS

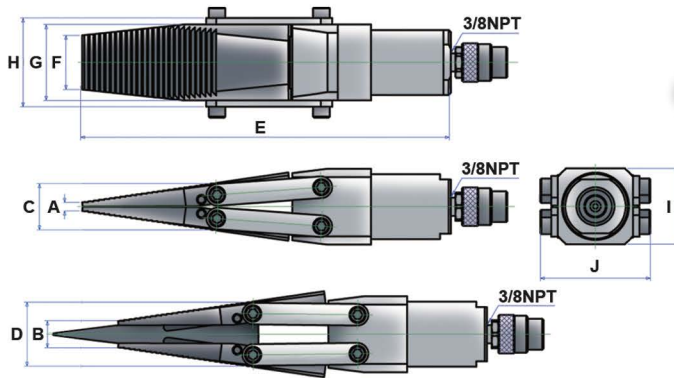

CAPACITY 15 ▶ 25 TON  
 SPREAD FROM 6 ▶ 25 (mm)  
 STROKES FROM 25 ▶ 65 (mm)  
 LOADS ARE SPREAD PERPENDICULARLY



ORDER CODE	CAPACITY (ton)	SPREAD (mm)		STROKE (mm)	C (mm)	D (mm)	E (mm)	F (mm)	G (mm)	H (mm)	I (mm)	J (mm)	WEIGHT (kgs)
		MIN (A)	MAX (B)										
SP07	15	6	16	25	36	46	232	31	45	55	Ø63	63	3.3
TL07	15	6	16	25	36	46	232	31	45	55	Ø63	63	3.3
SP15	25	8	25	65	43	59	342	50	70	82	70	102	7.8

# HYDRAULIC PORTABLE POWER KITS

ORDER CODE	CAPACITY (ton)	STROKE (mm)	KIT INCLUDES
PA904A	4 TON	100	<ul style="list-style-type: none"> <li>• HEAVY DUTY HAND PUMP WITH 6FT HOSE.</li> <li>• 4 TON 100mm (4") STROKE RAM.</li> <li>• 1/2 TON SPREADER RAM.</li> <li>• 4, 8, 12 &amp; 16" EXTENSION TUBES.</li> <li>• MALE CONNECTOR.</li> <li>• FLAT BASE, 90° V BASE, WEDGE HEAD, RAM TOE, PLUNGER TOE, RUBBER FLEX HEAD, SERRATED SADDLE.</li> <li>• BLOW MOULDED CASE.</li> </ul>
PA910A	10 TON	152	<ul style="list-style-type: none"> <li>• HEAVY DUTY HAND PUMP WITH 6FT HOSE.</li> <li>• 10 TON 152mm (6") STROKE RAM.</li> <li>• 1/2 TON SPREADER RAM.</li> <li>• 5, 10, 14 &amp; 19" EXTENSION TUBES.</li> <li>• MALE CONNECTOR.</li> <li>• FLAT BASE, 90° V BASE, WEDGE HEAD, RAM TOE, PLUNGER TOE, RUBBER FLEX HEAD, SERRATED SADDLE.</li> <li>• BLOW MOULDED CASE.</li> </ul>

CAPACITY 4 & 10 TON KITS  
 FORGED HIGH STRENGTH COMPONENTS  
 SNAP CONNECTIONS FOR QUICK ASSEMBLY

